

KOMATSU

SK820-8



Skid steer loader

Engine power
37.9 kW / 50.8 HP @ 2600 rpm

Operating weight
3140 kg

Operating capacity
950 kg

SK820-8



Engine power
37.9 kW / 50.8 HP @ 2600 rpm

Operating weight
3140 kg

Operating capacity
950 kg

Industry leading characteristics providing unrivalled customer value

Powerful and environmentally friendly

- Low-consumption EU Stage V engine
- Increased engine torque: + 7% *
- Increased operating capacity: + 3% *
- Increased drawbar pull: + 5% *
- Integrated Diesel Particulate Filter (DPF) with 6000 SMR cleaning interval

*vs previous generation

Total versatility

- 2 speed transmission
- Float function
- Auxiliary hydraulic circuit for attachments
- Universal quick-coupler
- "Super Flow" version (with drain line and electric connection) (option)
- Road homologation (option)

First-class comfort

- Newly designed cab
- Multifunction monitor with high resolution 3.5" LCD color display
- Suspension seat
- Pull-up sliding door, windows and heater (option)
- Air conditioning (option)

Safety first

- Secondary engine shutdown switch
- Seat belt caution indicator
- Anti-theft via monitor password lock

Easy maintenance

- Improved oil cooling filtration
- Extended maintenance information displayed on the monitor
- Tilttable cab
- 250-hour service interval

Komtrax

- Komatsu Wireless Monitoring System
- 4G mobile communications
- Error code display
- Integrated communication antenna

Powerful and environmentally friendly



Komatsu EU Stage V

The Komatsu EU Stage V engine is productive, dependable and efficient. With ultra-low emissions, it provides a lower environmental impact and a superior performance to help reduce operating costs and lets the operator work in complete peace of mind.

Komatsu CLSS

The CLSS (Closed-centre Load Sensing System) hydraulic circuit guarantees power, speed and perfect control to all movements, including simultaneous ones. The combination of the variable displacement pump and of CLSS allows operators to perform all required movements with maximum efficiency, regardless of the load or rpm.

Highly efficient

A self-levelling bucket is one of the many standard features of this Komatsu skid steer loader that make it highly efficient in any application. The accelerator pedal and a 2 speed transmission further increase operator productivity.

Total versatility

Vertical lift

The design of the vertical lift arm makes this model particularly suited for loading and unloading operations, particularly with a pallet fork. And because of this special design, the SK820-8 keeps the bucket reach constant throughout the whole trajectory. This allows higher tipping loads than for conventional models, along with increased ease-of-use and safety when working at maximum height.

Automatic Power Control device (APC)

Thanks to the APC device, the operator can always use the engine's full capacity, with no waste of power or overloads. It gives priority to the work equipment, makes the most of the residual power by sending it to the travelling motors, and prevents engine shutdown – even during the toughest operations.

Multiple attachments

A wide range of attachments can be used with this machine, on many different job sites. Perfect for an everyday use on farms, building yards, industrial environments or harbours, the Komatsu skid steer loader stands in for manual labour with unparalleled versatility. The SK820-8 is also available with an optional "Super Flow" hydraulic system, for using specialized attachments, and for extra power and flexibility.



First-class comfort



Perfect operator convenience

A spacious cab, with a wide entrance and comfortable seat, provides a level of comfort that is unmatched in this class of machines. On request, the SK820-8 can be equipped with an exclusive front door that fits under the roof, and with side windows and heating for maximum comfort in all seasons. The PPC servo-controls make the SK820-8 easy to use and grant unrivalled controllability.

New multi-function monitor with more information

A high-definition 3.5" LCD monitor integrated into the safety bar provides excellent visibility. The high-definition LCD panel is less affected by the viewing angle and surrounding brightness, ensuring excellent visibility. Various alerts and machine information are displayed in a simple format. Useful information such as operation records, machine setting and maintenance data are also provided. The operator can easily switch screens.



Information & communication technology



Knowledge

You get quick answers to basic and critical questions about your machines – what they're doing, when they did it, where they're located, how they can be used more efficiently and when they need to be serviced. Performance data is relayed by wireless communication technology (satellite, GPRS or 4G depending on model) from the machine to a computer and to the local Komatsu distributor – who's readily available for expert analysis and feedback.

Convenience

Komtrax enables convenient fleet management on the web, wherever you are. Data is analysed and packaged specifically for effortless and intuitive viewing in maps, lists, graphs and charts. You can foresee eventual maintenance issues and required spare parts, and troubleshoot a problem before Komatsu technicians arrive on site.



The way to higher productivity

Komtrax uses the latest wireless monitoring technology. Compatible on PC, smartphone or tablet, it delivers insightful and cost saving information about your fleet and equipment, and offers a wealth of information to facilitate peak machine performance. By creating a tightly integrated web of support it allows proactive and preventive maintenance and helps to efficiently run a business.

Power

The detailed information that Komtrax puts at your fingertips 24 hours a day, 7 days a week gives the power to make better daily and long-term strategic decisions – at no extra cost. Problems can be anticipated, maintenance schedules customised, downtime minimised and machines kept where they belong: working on the jobsite.



Easy maintenance

Easy access to inspection points

Routine maintenance and check-ups can be performed by simply opening a rear bonnet that also allows the user to clean the inclinable radiators. For extra servicing, the tilting cab offers complete access to the transmission and to the main components of the hydraulic system. Special self-lubricating bushings increase the greasing intervals for all pins up to 250 hours.



Easy access to daily maintenance points



Thanks to the internal cab bonnet, extra servicing of the main valve can be done quickly without tilting the cab



Basic maintenance screen on the 3.5" multi-colour monitor

Highest reliability and safety

Safety sensors

To reduce the risk of injuries for the operator, a sophisticated system of sensors located on the safety bars and on the seat prevents all machine movements by automatically braking on the transmission and inhibiting the PPC controls. The ROPS-FOPS cab, the excellent dynamic stability of the machine and a 360° visibility combine to give the operator complete confidence in any situation.



Brakes

The service and parking brakes are incorporated into the travel motors. They are hydraulic negative action brakes and can be set "on" or "off" with a button located on the board to the left of the operator. The brakes are always "on" when the engine is not running.

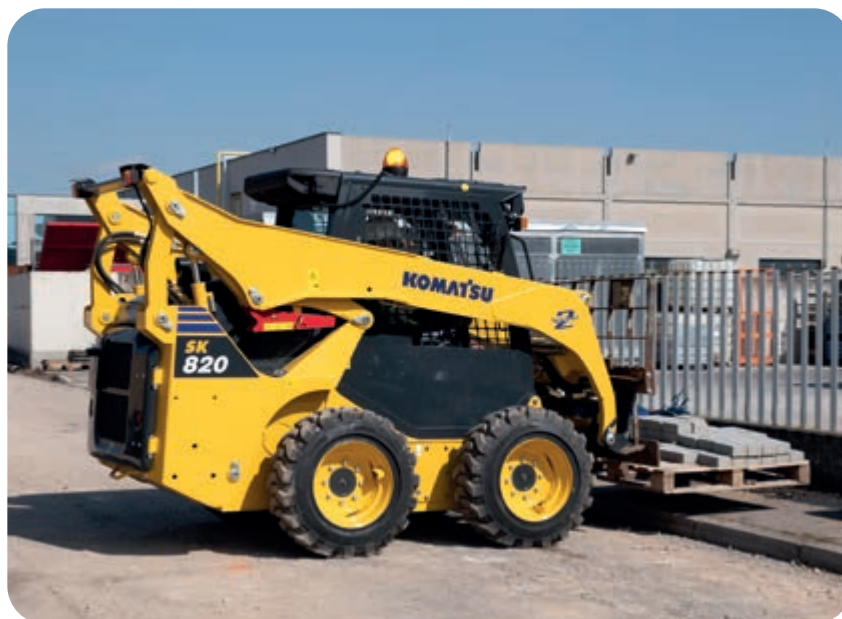

Excellent view on work equipment and job site



Secondary engine shutdown switch



Work equipment safety lock lever

Specifications

Engine

Model	Komatsu S4D86E-7MFD
Type	Common rail direct injection, water-cooled, emissionised, turbocharged, after-cooled diesel
Engine power	
at rated engine speed	2600 rpm
ISO 14396	37.9 kW / 50.8 HP
ISO 9249 (net engine power)	36.0 kW / 48.3 HP
No. of cylinders	4
Bore × stroke	86 × 90 mm
Displacement	2.09 l
Max. torque / engine speed	168 Nm / 1690 rpm
Cooling system	Water
Fuel	Diesel fuel, conforming to EN590 Class 2/Grade D. Paraffinic fuel capability (HVO, GTL, BTL), conforming to EN 15940:2016

Transmission

Type	Hydrostatic
Pumps	2 × variable displacement
Hydraulic motors	2 × axial pistons
No. of speeds	2
Max. travel speed	16 km/h
Automatic working and parking brakes	

Hydraulic system

Type	Komatsu CLSS
Hydraulic pump	Gear pump
Max. pump flow	62 l/min
Max. operating pressure	206 bar
Max. pump flow - "Super Flow" (option)	100 l/min

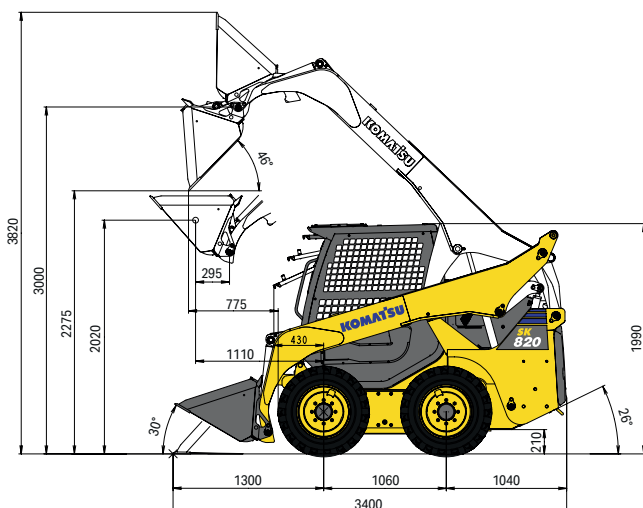

Loader

Operating capacity (standard bucket)	950 kg
with add. counterweight	1030 kg
Tipping load (standard bucket)	1900 kg
Standard bucket capacity (ISO 7546)	0.40 m ³
Bucket breakout force (ISO 14397)	1450 daN (1478 kg)
Operating capacity with pallet forks	690 kg
Max. loading height with forks	2850 mm
Max. reach with forks	1555 mm

Operating weight (appr.)

Operating weight, including open cab, operator (75 kg), liquids, filled tank and standard equipment (without bucket)	2958 kg
Standard bucket (1730 mm)	+ 182 kg
Additional counterweight	+ 126 kg
Front door	+ 40 kg

Service refill capacities

Fuel tank	67 l
Cooling system	9.0 l
Engine oil	7.5 l
Hydraulic system	27 l
Final transmission	14.4 l

Environment

Engine emissions	Fully complies with EU Stage V exhaust emission regulations
Noise levels	
LwA external	101 dB(A) (2000/14/EC Stage II)
LpA operator ear	85 dB(A) (ISO 6396 dynamic test)
Vibration levels (EN 12096:1997)	
Hand/arm	≤ 2.5 m/s ² (uncertainty K = 1.2 m/s ²)
Body	≤ 0.5 m/s ² (uncertainty K = 0.2 m/s ²)
Contains fluorinated greenhouse gas HFC-134a (GWP 1430). Quantity of gas 0.7 kg; CO ₂ equivalent 1.0 t	

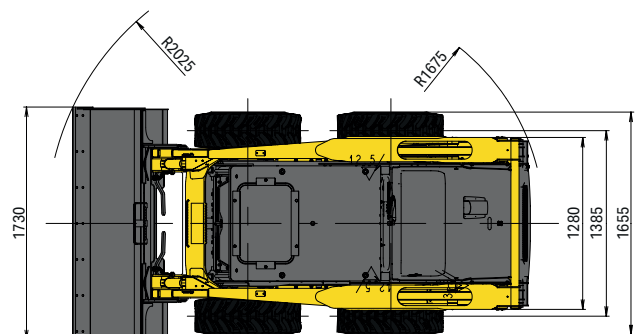

Standard and optional equipment

Engine

Komatsu S4D86E-7MFD turbocharged common rail direct injection diesel engine	●
EU Stage V compliant	●
Automatic two-speed travel control	●
Alternator 12 V / 55 A	●
Batteries 12 V / 80 Ah	●

Hydraulic system

Komatsu closed-centre load sensing (CLSS) hydraulic system	●
PPC control lever and pedals for steering and travel	●
Auxiliary hydraulic circuit for attachments	●
Bucket floating function	●
"Super Flow" version with 3 elements main valve (with drain line and electric connection)	○
Additional drain line for standard flow hydraulics	○

Tyres

10-16.5 10PR	●
10-16.5 10PR narrow tread tyres	○
10-16.5 10PR HD tyres	○
31×10-20 solid tyres	○

Safety equipment

Electric horn	●
Audible travel alarm	●
Battery negative pole disconnection	●
Rear-view mirrors	●
Secondary engine shutdown switch	●
Dual lock system for PPC controls	●
Seat belt caution indicator	●
Rotating beacon	○
FOPS Class 2 cab	○
Accessories for road homologation	○

LED lighting system

2 front working lights on cab	●
2 rear working lights on cab	○

Cabin

ROPS / FOPS (Class 1) tilting cab	●
Adjustable deluxe suspension seat with seat belt	●
Safety bar with incorporated 3.5" multi-colour monitor	●
Accelerator pedal	●
12 Volt power supply	●
Lifting hooks	○
Pull-up type sliding door	○
Sliding side windows	○
Heater	○
Air conditioning	○

Service and maintenance

Automatic fuel line de-aeration	●
Double element type air cleaner with dust indicator and auto dust evacuator	●
Komtrax – Komatsu wireless monitoring system (4G)	●

Work equipment

Universal mechanical quick-coupler	●
1730 mm bucket with or without teeth	●
1580 mm bucket with or without teeth	○
Cutting edge on teeth	○
Bolt-on cutting edge	○
Pallet forks	○

Other equipment

Counterweight	●
Bucket self leveling	●
Mudguards	○
Additional modular rear counterweight (6 pieces, total 126 kg)	○
Customised paint	○
TÜV + TBG version	○

Further equipment on request

- standard equipment
- optional equipment

This specification sheet may contain attachments and optional equipment that are not available in your area. Please consult your local Komatsu distributor for those items you may require. Materials and specifications are subject to change without notice.

Your Komatsu partner:

KOMATSU

[komatsu.eu](https://www.komatsu.eu)

